

BHARAT HEAVY ELECTRICALS LIMITED, BHOPAL**TRANSFORMER ENGINEERING DEPARTMENT**

FORM NO: TRE-2003A

Sht 1 of 2 sheet

ANNEXURE TO INDENT-CUM-ENQUIRY - **240614168**

DTD.:-

DESCRIPTION OF ITEM

**: COPPER WINDING WIRE-GLUED CONTINUOUSLY TRANSPOSED CW
FOR 500 MVA, 765_{N3}/400_{N3}/33 KV, 1-PH ICT.**



WORK ORDER NO.

: 62007-F-512-22

CUSTOMER

: MEIL**TABLE OF WEIGHTS & DIMENSIONS OF COPPER WINDING WIRE - GLUED CONTINUOUSLY TRANSPOSED CW**

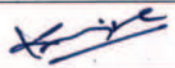
			ITEM 1	ITEM 2	ITEM 3	ITEM 4	ITEM 5	ITEM 6	ITEM 7
1.	CABLE SIZE	mm× mm	17//1.80 × 10.00	15//1.50 × 6.90		7//1.72 × 6.90		37//1.50 × 3.00	29//2.00 × 6.00
2.	RADIAL PAPER	mm	0.48	0.64		1.04		0.48	1.04
3.	PAPER QUALITY a) Inner layer(s) b) Outer layer(s)		AS PER SPECIFICATION TRE218	AS PER SPECIFICATION TRE218		AS PER SPECIFICATION TRE218		AS PER SPECIFICATION TRE218	AS PER SPECIFICATION TRE218
4.	GRADE OF ENAMEL	--	F & EPOXY COATED	F & EPOXY COATED		F & EPOXY COATED		F & EPOXY COATED	F & EPOXY COATED
5.	0.2% PROOF STRESS	MPa	170 (CPR2/BS1432) (Tol. +40, -0 MPa)	220 (CPR3/BS1432) (Tol. +40, -0 MPa)		220 (CPR3/BS1432) (Tol. +40, -0 MPa)		220 (CPR3/BS1432) (Tol. +40, -0 MPa)	140 (CPR1/BS1432) (Tol. +40, -0 MPa)
6.	MAXIMUM COVERED SIZE								
	i) RADIAL	mm	19.50	15.37		10.12		34.44	35.98
	ii) AXIAL	mm	21.98	16.1		16.90		7.9	15.06
7.	MINIMUM COVERED SIZE								
	i) RADIAL	mm	17.72	13.74		9.14		30.72	33.03
	ii) AXIAL	mm	21.05	15.14		15.94		7.13	14.18
8.	NO. OF DRUMS		4	2	2	4	4	4	6
9.	LENGTH PER DRUM	m	98.0	1598.5	1241.5	1953.5	1526.5	189.0	115.5
10.	TOTAL BARE WEIGHT	Kg	1046.0	4325.5	3359.5	5601.0	4377.0	1067.5	2081.0
11.	TOTAL COVERED WEIGHT	Kg	1078.0	4524.0	3513.5	6079.0	4750.0	1120.5	2180.0
12.	COVERED WEIGHT PER DRUM	Kg	269.5	2262.0	1756.75	1519.75	1187.5	280.13	363.33
13.	MINIMUM WINDING DIAMETER/ TRANSPOSITION PITCH	mm	1484.0 / 137.0	1714.0 / 160.0		2290.0 / 108.0		1484.0 / 126.0	1632.0 / 177.0
14.	CROSS SECTION AREA OF SINGLE STRAND	mm ²	17.64	10.13		11.508		4.28	11.64

REV	DATE	ALT CKD	REV	DATE	ALT- CKD-	REV 00	NAME	SIGN	DATE
						PREP	PP		21.10.2021
						CKD	SS		21.10.2021

DWI/TCB/TRE/010

BHARAT HEAVY ELECTRICALS LIMITED, BHOPAL
TRANSFORMER ENGINEERING DEPARTMENT

FORM NO: TRE-2003A

Sht 2 of 2 sheet

NOTES:

1. Length per drum should not be less than specified for all drums except the drums from which sample has been taken.
2. Items 1 to 7 must conform to specification TRE-036 & AA 28129 with changes as above (specification copy attached). Resistivity of copper at 20 degC to be max. $0.01777 \Omega \text{ mm}^2/\text{m}$
3. The paper insulation shall be conforming to specification TRE218 (specification copy attached). Paper to be of M/s Weidmann, Switzerland / M/s Smurfit Munksjo, Sweden make (MEIL approved make).
Minimum no. of layers of paper covering shall be as under
 - Item -1 & 6 : 3 nos. of 63 micron thick paper & 4 nos. of 75 micron thick paper.
 - Item - 2 & 3: 4 nos. of 50 micron thick paper & 7 nos. of 63 micron thick paper.
 - Item - 4, 5 & 7: 7 nos. of 63 micron thick paper & 8 nos. of 75 micron thick paper.
4. Quality plan no. QC/TCB/QAP/B0/55 Rev.01 and MEIL approved MQP: QA/TCB/31/744, Rev.03 shall be followed (Copy attached).
5. Items 2, 3, 4 & 5 to be supplied with wax coating as per Cl. No. 10.3.5 of specification AA28127 (specification copy attached).
6. In Item 7, tags to be provided at 56 meters from start of each drum.



**EPOXY COATED PAPER COVERED CONTINUOUSLY TRANSPOSED COPPER CABLE
(0.1% PROOF STRESS)**

1. This Specification governs the quality of continuously transposed Copper cable exactly similar to specification AA28129 except following modification /additional requirements. The cable shall not be manufactured earlier than 30 days from date of dispatch since it has a limited shelf life.
In case on any conflict between AA28129 & TRE036, TRE036 shall prevail.
2. An extra coating of Semi cured ('B' stage) epoxy enamel shall be given over PVA enamel) on all the conductors. The coating shall be tack-free at room temperature and it shall be able to fully cure when heated at 130°C for 6 hours. The increase in dimension due to epoxy coating shall be 0.06 mm ± 0.02 mm and due to enamel coating increase in dimensions shall be 0.085 ± 0.025 mm.
3. Nominal value of 0.1% proof stress of conductor shall be specified on order.
4. Tolerance on overall width and thickness (bare strip + PVA enamel + epoxy) of individual conductor shall be as per Annexure 2 of this document.
5. Paper used for outer coverings shall comply to AA 21111 or as specified in order.
6. Insulation test between strips as per Cl. 12.1 of AA 28129.
7. In order to check the bonding strength of epoxy powder coating , samples after curing should be subjected to "Radial bending test" as per enclosed Annexure-1.
8. Test certificate shall be issued indicating observed and specified values of dimension and test as per Cl. 13 of AA 28129 and C1. 6 & 7 of TRE: 036. Packing and marking will be as per Cl. 14 of AA 28129. Packing shall be seaworthy and drums should be kept in a container/ Crate to avoid ingress of moisture in transit.

REV 08	DATE 08.9.18	ALT CHD	REV 07	DATE 05.9.18	ALT CHD	-sd- -sd-	REV 04	NAME	SIGN	DATE
Annexure 1 & 2 updated.			Clause 5,6,7,8 of Annexure-2 revised.				PREP	S.K.MAHAJAN	-sd-	09.12.07
							APPD	J.S.KUNTIA	-sd-	09.12.07
DWI/TCB/TRE/010										

Handwritten signature

ANNEXURE-1

RADIAL BENDING STRENGTH TEST FOR EPOXY BONDED CTC CABLE

1. Determination of bonding strength radial bending strength test

The bonding property is the property of proper bonding of various strands of CTC after curing.

In order to establish the proper bonding the test method as per CI 4.0 shall be followed. From the tests a curve of "P" as function of "f" is obtained, where P is the force on the cable [N] f is the deflection or flexion [mm]

The curve gives:

- The value of the maximum load P₂
- The ratio K corresponding to the ratio between the half of the maximum load and the corresponding deflection: $K = P_1/f_1$

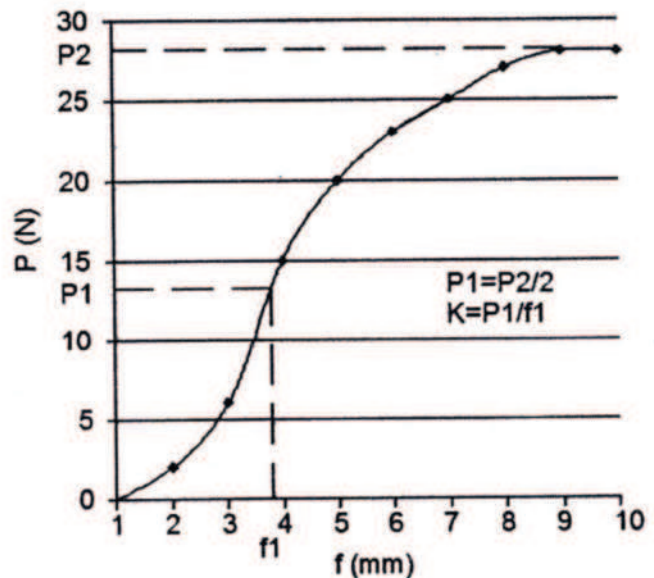

RADIAL BENDING STRENGTH

2. Limitations & Assumptions

- The ratio between radial dimension RD of the bare CTC and axial dimension AW of the bare CTC is:
< 5.0 for CTC made with not bondable strands
< 4.5 for CTC made with bondable strands

$$RD/AW = \frac{((n+1)/2)(t+e+Ie)}{2(b+e+Ie)}$$

where, e+Ie = double-sided thickness of enamel and epoxy if any

- The radial strand dimension $t \leq 3.2$ mm
- The axial strand dimension $b \leq 12.5$ mm

3. Calculation & Tables

The value of $P_2 = \epsilon \times b \times n^2 \times t^2 \times 9.81/d$ (N)

Where:

ϵ = coefficient taking into account the number of strands of the CTC as per Table-1

d = distance between the supports

= 150 mm for CTC up to 31 strands

= 300 mm for CTC with more than 31 strands

The average value of K shall be greater or equal to the value calculated as

$$K = \eta \times \epsilon \times b \times t^3 \times ((n-2)^3 + 2)/d^3 \text{ (N/mm)}$$

Handwritten signature

Where,

E is the Young modulus of the copper strand & its value is:

- For $R_p0.2\% \leq 180$ MPa is considered equal to 80000 N/mm²
- For $R_p0.2\% > 180$ MPa and $R_p0.2\% \leq 230$ MPa is considered equal to 100000 N/mm²
- For $R_p0.2\% > 230$ MPa is considered equal to 110 000 N/mm²

η is coefficient depending on the number of strands as per Table-2

Table 1 (For ϵ)

Number of strands	$R_p 0.2\% > 230$ MPa	$230 \text{ MPa} \geq R_p 0.2\% > 180$ MPa	$R_p 0.2\% \leq 180$ MPa
Up to 23	7.0	5.4	4.4
25	6.6	5.1	4.2
27	6.2	4.8	4.0
29	5.8	4.3	3.7
31	5.0	3.9	3.2
33 to 41	4.6	3.5	3.0
43 to 51	4.0	3.1	2.8
53 to 61	3.6	2.9	2.4
63 to 71	3.2	2.6	2.0
Over 73	2.9	2.2	1.8

Table 2 (For η)

Number of strands	$t < 2$ mm	$t \geq 2$ mm
Up to 15	0.90	0.90
17 to 23	0.90	0.70
25	0.75	0.50
27	0.60	0.45
29	0.55	0.40
31	0.35	0.25
33 to 41	0.40	0.24
43 to 51	0.24	0.22
53 to 61	0.19	0.17
63 to 71	0.17	0.14
Over 73	0.14	0.12

4. Test Method

- 4.1 **Specimen** : 3 nos. CTC specimens as below shall be prepared for each supply.
Length = 450 mm for CTC with $n < 33$
Length = 600 mm for CTC with $n \geq 33$
- 4.2 **Sampling** : Each specimen shall be cut from the original drum without bending the cable. Strands shall be locked in a suitable way.
- 4.3 **Thermal treatment** : The specimens shall by means of a device be shaped to a diameter of 1000 mm and axially loaded with side jaws. Treatment in an oven with air circulation at a temperature of $120 \pm 5^\circ\text{C}$ for 24 hours or at $110 \pm 5^\circ\text{C}$ for 48 hours. Cooling at room temperature for at least 6 hours.

Handwritten signature

4.4 Test Method

Each sample shall be placed over the cylindrical supports of the flexion machine-with the concave part towards the top and the convex part towards the bottom of the flexion machine.

In case of CTC with ratio $RD/AW > 3$, it is convenient to take the specimen in the correct position using suitable side-roll supports, without applying any stress.

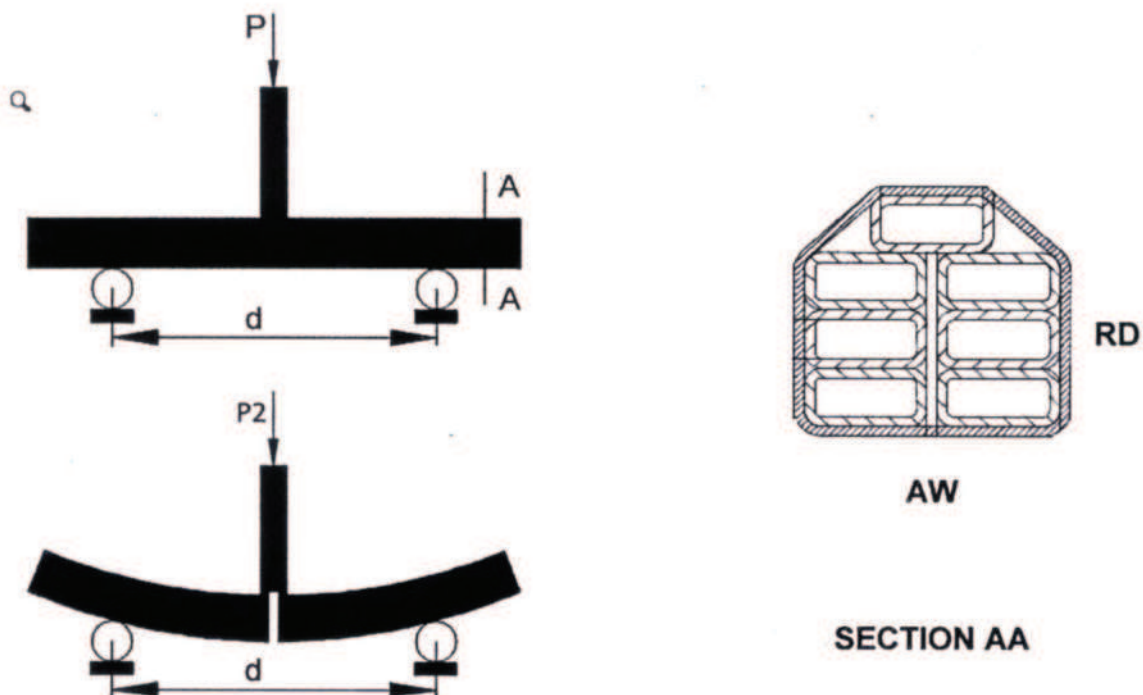

5.0 **Results** - The parameters $P2$ & K are calculated and average value shall be greater than the values required in Cl. 3.0.

6.0 Detail of test set up:

Flexion machine is composed by a dynamometer, a support device and a plotter. Support device consists of two cylindrical supports at distance of 150 or 300 mm depending on the number of strands of the CTC.

- 150 mm for CTC with $n < 33$

- 300 mm for CTC with ≥ 33

The dynamometer is used in compression with a jaw connected to a cylinder in order to apply the flexional load in the middle of the specimen. The plotter is used in order to plot the curve of load and flexion. The support device is placed at the bottom of the dynamometer and the arrow is measured with a strain gauge connected to a touch sensor to the bottom of the specimen. The touch sensor shall touch an area coincident with the width of the strand, when the spring of the touch sensor is put in tension. On the plotter the zeroing of the paper is done. The load is gradually applied to the specimen, plotting the diagram of load and arrows.

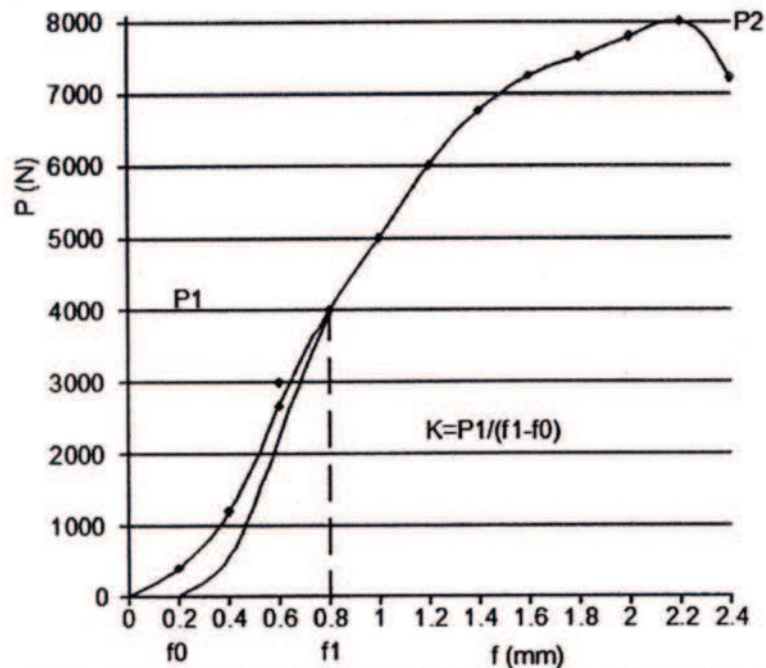

Example : $K = P1 / (f1 - f0) = 4000 / (0.8 - 0.2) = 6660 \text{ N/mm}$

In order to keep the measurement independent of settling of paper and transpositions, the following test procedure is prescribed:

- Make a dummy test with one of the specimens. This test gives a maximum P2 value where the bonding breaks. $P1 = P2/2$ is calculated.
- On each of the other specimens the load shall be raised up to the theoretical value P1 and then decreased down to zero. Gives a remaining small flexion f0, which is the new, zero point for the flexion.

A load is then applied up to the break of the bonding properties of the specimen. This point is the P2 value for that specimen and is recognized in the diagram when the plotting mark is going towards the bottom showing a significant loss of bonding adhesion.

$P1 = P2/2$ is calculated.

- From the load/flexion curve, corresponding P1 and f1 values can be read. Calculate the ratio $K = P1 / (f1 - f0)$

ANNEXURE-2

COVERED DIMENSIONS OF TRANSPOSED CABLES

1.	Transposing Factor (Tp)		$T_p = \pi \times ID / (n \times b)$
2.	Nominal Covered Axial Width (AW)		$AW = 2 \times (b + e + le) + P + l_{cp}$
3.	Tolerance on AW		+0.15 / -0.10
4.	Nominal Covered Radial Depth (RD)		$RD = (n+1)/2 \times (t + e + le) + P$
5.	Tolerance on RD		
	n	If $T_p \geq 7$ & $t < 2.00$ & $R_p \leq 170$ MPa	If $T_p \geq 5$ & $t \geq 2.00$ & $R_p > 170$ MPa
	≤ 21	+ 0.30 / -0.20	+ 0.50 / -0.15
	23 to 35	+ 0.40 / -0.25	+ 0.60 / -0.25
	37 to 55	+ 0.80 / -0.40	+ 1.30 / -0.40
	> 55	+ 1.10 / -0.60	+ 1.40 / -0.50
6.	Tolerance on dimension t or b		
		≤ 3.15	± 0.030
		3.16 to 6.30	± 0.050
		6.31 to 12.50	± 0.070
		12.51 to 16.00	± 0.100
7.	Overall covered dimension AW & RD shall be measured under pressure of 100 N/cm ² .		
8.	Abbreviation		
	<p>ID = Inner diameter of winding n = No. of single strands in transposed cable b = Nominal width of bare single strand t = Nominal thickness of bare single strand e = Nominal increase due to enamel le = Nominal increase due to epoxy P = Nominal thickness of paper (both side) l_{cp} = Inter column paper, if specified (100 μm) R_p = 0.1% proof stress value</p> <p style="text-align: right;"><i>(All dimension are in mm, if not specified)</i></p>		



CORPORATE PURCHASING SPECIFICATION

AA 28129

REV NO . 04

PAGE 1 OF 9

**PAPER COVERED CONTINUOUSLY TRANSPOSED COPPER CABLE
(0.1% PROOF STRESS)**

1. GENERAL :

This specification governs the quality requirements of paper covered continuously transposed copper conductor (CTC) incorporating a number of individual work hardened copper strips insulated with a polyvinyl – acetal based enamel of fine grade and covered over all with not less than three layers of paper and suitable for use in hot insulated oil. Paper shall conform to BHEL corporate purchase specification (CPS) No. AA 21111 or AA 21116. The material in insulating oil have temperature index of 105 .

2. APPLICATION :

Used for windings of Transformers .

3. COMPLIANCE WITH NATIONAL STANDARDS

There is no National Standard for this type of material . However assistance has been derived from the following standards .

IS : 13370 Pt. 17, 1996/ - Specification for particular type of winding wires -
IEC : 60317-17,1970 Pt. 17 - Polyvinyl Acetal enameled Rectangular .
Copper Wires. Class 105

IS : 13730 Pt.27 – 1996 / - Specification for particular Type of winding wires
IEC : 60317 - 27 – 1990 Pt. 27 - Paper covered Rectangular Copper Wire .

4. TEST SAMPLES :

4.1 Paper :

The supplier shall send the test certificate for papers for all the tests as per BHEL Corporate Purchase Specification (CPS) No. AA 21111 or AA 21116 for our approval. The test report shall be sent for each lot of paper and of different thicknesses received from the paper mill , which are to be used in the manufacture of BHEL paper covered continuously transposed copper cable .

In the absence of proper test certificate 20 sheets of size 300X300 mm of paper from each lot and of different thicknesses shall be supplied for out testing.

Revision : CI.34 .1.19 of MOM of MRC (E)			APPROVED : INTER PLANT MATERIAL RATIONALISATION COMMITTEE- MRC (E)		
Rev.No. 04	Amd.No.	Reaffirmed	Prepared BHOPAL	Issued Corp. R&D	Dt.of Ist Issue Aug . 1987
Dt :19.05.07	Dt:	Year:			

COPYRIGHT AND CONFIDENTIAL
The information on this document is the property of Bharat Heavy Electricals Limited .
It must not be used directly or indirectly in any way detrimental to be interest of the company



CORPORATE PURCHASING SPECIFICATION

AA 28129

REV NO. 04

PAGE 2 OF 9

4.2 Finished Conductor

3 metre long sample of CTC shall be supplied for testing and inspection.

5. CONDUCTOR:

5.1 CTC of any size given in Transformer standard sheets shall be ordered. Maximum and minimum dimensions of bare cable shall be as per these individual orders. Conductor size, No. of parallels and radial paper covering shall be stated on the order.

5.2 Radial insulation shall be from 0.20 to 3.0 mm, both inclusive.

5.3 Bunched CTC consisting of 2 or more individual stacks of any size indicated in Transformer Standard sheets shall also be ordered whenever required.

6. LENGTH & WEIGHT OF CABLE:

6.1 The total weight of cable, the length of cable per drum and the total No. of drums shall be as stated on the order. Length of cable per drum specified in our order is very important and so, it shall neither be less nor more than the specified.

6.2 Weights indicated in our orders are nominal and can vary within ± 2 percent considering allowed tolerances on dimensions and on corner radius.

Excess weights more than 2 percent shall not be admissible under any circumstances.

7. TYPE OF ENAMEL COVERING:

Fine grade. However in exceptional cases when medium grade of covering is required, it shall be stated on the order.

8. CONDUCTOR:

8.1 Grade of Material:

The conductor shall be manufactured from ETP grade copper conforming to BHEL Corporate Purchasing Specification (CPS) AA 12024.

Note : Manufacture of the Copper conductors from continuous cast copper bars is preferable provided all other acceptance parameters and conditions remains same.

The conductor shall fully conform to IS : 13730 Pt. 27 - 1996 except 0.1% proof stress and resistance. The 0.1 % Proof Stress of the conductor after removal of paper when tested as per IS:1608 shall be as given below :

<u>Nominal Value</u>	<u>Tolerance</u>
115, 135 & 145 Mpa .	+15% , - 10%



CORPORATE PURCHASING SPECIFICATION

AA 281 29

REV NO.

PAGE 3 OF 9

Tests shall be carried out on one sample taking 50 mm gauge length .However the conductor with any other nominal value of 0.1% proof stress can also be ordered .

8.2 ELECTRICAL RESISTIVITY:

The resistivity at 20 °C, when measured directly on the sample in "as received" condition shall not be greater than 0.01777 ohm/mm²/m. Refer Appendix "B of IS : 613 for temperature correction factor.

8.3 Enameled conductor :

The enameled conductor shall comply with fine grade of covering to IS :13730 Pt. 17, I with the exceptions as given below :

8.4 Joints :

8.4.1 Joints in Bare Conductor :

Joints shall not be made in the conductor after it is drawn . Any joint made during the drawing process shall be resistance welded .

8.4.2 Joint in Enameled conductor : I

If a joint in the enameled conductor becomes unavoidable due to breakage accidental stoppage of machine or when the specified length is in excess of the capacity of transposing machine bobbins, it shall be made by resistance welding , care being taken to ensure that the joint is made sound . All surplus weld shall be removed by filing and the joint finished with emery cloth / paper to give a smooth clean surface after I which it shall be patch enameled . Any joint shall be insulated from the adjacent strips by a single piece of 100 micron thick paper half overlapped . Joints in the individual strips shall be staggered so that the distance between individual joints along the cable shall not be less than 150 mm. A red tag shall be tied at the joint portion of cable for identification and inspection . Any such joint shall be made only after prior approval of BHEL .

9. PAPER:

9.1 Grade of Paper:

Kraft paper shall conform to BHEL Corporate Purchasing specification (CPS) No. AA 21111 or AA 21116. If kraft / manila mixture or any other paper is used, it shall conform to BHEL Corporate Purchasing Specification (CPS) No. AA 21111 or AA 21116.

9.2 Thickness:

The thickness of paper shall be within limits of 50 and 140 um both inclusive.

**10. CONSTRUCTION OF TRANSPOSED CABLE:****10.1 Cleanliness of Enameled Conductor:**

The enameled conductor shall be free from copper dust and other extraneous matter prior to transposing and covering with paper.

10.2 Transposition of Enameled Conductor:

The cable shall be manufactured from any odd number of enameled conductors from a minimum of 5 to a maximum of 31, according to the size of the individual conductor and the overall size of the cable as specified in the order.

The cable shall be formed by placing the strips into two stacks, the stacks, being edge to edge and the whole group of strips being continuously transposed along the length of the cable.

The pitch of successive transpositions shall be approximately 15 times the width of bare strip subject to a minimum of 50 mm. Lay i.e. the distance over which a strip resumes its original position in the conductor shall be equal to pitch multiplied by the number of strips.

For cables of radial depth 10 mm and above it shall have an intercolumn paper (paper spacer) inserted between the vertical stacks of strip. This paper shall comply with clause 9 and thickness shall be 100 um. Width of the paper spacers shall not be less than the value calculated from the following formula.

$$\text{Width} = \frac{(\text{Number of strips} - 1)}{2} \times \text{thickness of enameled strip}$$

10.3 Application of Paper Covering:**10.3.1 General:**

Each layer of paper shall be continuous, firmly applied and substantially free from creases. No bonding or adhesive material shall be used except to anchor the ends of paper. Any such bonding or adhesive material shall have no deleterious effect on transformer oil, insulating paper, or electric strength of the covering. When papers of different thickness are used, the outermost paper shall be the thickest. The thickness of the paper shall be progressively increased from the innermost to the outermost layer.

10.3.2 Width of paper:

The width of paper shall be within the limits of 15 and 40 mm, both inclusive.

10.3.3 Arrangement of layers:

All the layers shall be applied in the same direction, all except the two outermost layers shall be butt wound and the two outermost layers shall be applied together with a staggering of 50% so that they are interlocked giving 50% overlap effect. Within each group the positions of the butt joints of any layer relative to the layer below shall be progressively displaced by approximately 30 percent of the paper width.



10.3.4 PAPER THICKNESS FOR BUTT AND OVERLAP INTERLOCKED WOUND LAYERS:

Thickness of paper for butt wound layers shall be between 50 μm and 100 μm (both inclusive) Two outermost overlap interlocked layers shall be wound with paper of thickness between 75 and 125 microns (both inclusive). However, when radial insulation is 2.2 mm or more, 140 μm paper for two outermost layers is allowed to avoid two paper covering operations due to availability of a maximum of 24 paper heads in the lapping machine of same manufactures. Special extensible high density and high mechanical strength paper meeting the requirements of clause 9 can be used in the two outermost interlocked layers.

11. DIMENSIONS OF TRANSPOSED CABLES :

11.1 Method of Calculating Maximum Bare Axial Width (AW) :

$$AW = 2(b + e) + F + \text{inter column paper if specified (100 } \mu\text{m thick)}$$

Where

$$AW = \text{Max. bare axial width of transposed cable.}$$

$$b = \text{Maximum axial width of bare individual conductor} \\ = \text{Nominal width} + \text{Tolerance (from table 1 below)}$$

$$e = \text{Maximum increase in dimension due to enameling} \\ (\text{as per IS : 13730 Pt. 0 /Sec. 2 : 1993 (R-2003), IEC 60317-0-2:2005}) \\ = 0.11 \text{ mm for fine grades of covering}$$

$$F = \text{Free space allowance} = 0.4 \text{ mm}$$

Table 1 - Tolerances on Nominal Dimensions - (IS :13730 Pt. 27 : 1996)

Dimension (Width or Thickness), mm		Tolerances \pm mm
Over	Up to and including	
-	3.15	0.030
3.15	6.30	0.050
6.30	12.50	0.070
12.50	16.00	0.100

11.2 Method of calculating Maximum Bare Radial Depth (RD)

$$RD = \frac{N+1}{2} (T + e) + \text{free space allowance (from Table 2)}$$

Where

$$RD = \text{Maximum bare radial depth of Transposed Cable.}$$

$$T = \text{Maximum thickness of bare individual conductor} \\ = \text{Nominal thickness} + \text{Tolerance (from table 1 in cl.11.1)}$$

$$N = \text{Number of conductors in parallel}$$

$$e = \text{Maximum increase in dimensions due to enameling} \\ (\text{as per IS : 13730 Pt. 0/Sec 2 : 1993 (R 2003), IEC 60317-0-2 : 2005}) \\ = 0.11 \text{ mm for fine grade of covering.}$$



TABLE 2 - FREE SPACE ALLOWANCE - RADIAL DEPTH (mm)

No. of conductors	Free space allowance radial depth, mm	
	Thickness 1 -- 2 mm	Thickness 2.1 -- 3.15 mm
5 -11	0.28	0.63
13	0.30	0.70
15	0.33	0.78
17	0.36	0.85
19	0.39	0.90
21	0.42	1.00
23	0.44	1.05
25	0.50	1.15
27	0.55	1.25
29	0.60	1.40
31	0.65	1.50.

11.3 Method of Calculating Maximum Axial Width & Radial Depth with Paper Covering:

$$\begin{aligned}\text{Maximum covered Axial Width} &= AW + t \\ \text{Maximum covered Radial Depth} &= RD + t\end{aligned}$$

Where AW is taken from Clause 11.1

RD is taken from Clause 11.2

t = nominal increase in dimensions due to paper covering taken from Cl. 11.4.

11.4 Increase in Dimensions due to paper covering:**11.4.1 Increase in Dimensions:**

The increase in dimensions due to covering shall have tolerance indicated below:

Increase due to covering (mm)		Tolerance %
Over	Up to & including	
-	0.5	+0 - 10
0.5	1.3	+0 - 7.5
1.3	-	+0 - 5

11.4.2 Measuring Equipment :

The measurement shall be made with a suitable ratchet micrometer. The spindle and anvil of the micrometer shall have a diameter of 5 to 8 mm.

Khire



CORPORATE PURCHASING SPECIFICATION

AA 28129

REV NO. 04

PAGE 7 OF 9

11.4.3 Measuring Method:

Covered Dimension shall be measured at three positions not less than 100 mm apart.. The measurements shall be made on completely straight parts of the transposed cable. The measurement shall include at least one over lap. The covering shall be removed by any method which does not damage the conductor for three positions used for the measurement of "Covered Dimensions" and "Bare Dimensions" measured at these positions. The average of the three results shall be reported as "bare dimension". The difference between "Covered Dimension" and the "Bare Dimension" shall be reported as the increase in dimension due to covering.

11.4.4 Counter Check:

The increase in dimension due to covering shall also be counter checked by adding up the thickness of paper used in each layer. The thickness of paper shall be measured by dead weight micrometer conforming to IS: 1060 (Part 1) by stacking the tapes of paper one above the other. Paper tape shall not be folded to form two or more tapes. Length of paper tapes shall not be less than 150 mm. Five measurements shall be made distributed over the stack. The paper thickness shall be computed by dividing by five the mean of five readings.

Radial insulation so computed in 11.4.4 shall not be less than the minimum allowed (considering the appropriate tolerance) as per 11.4.1.

12. TESTS ON FINISHED CABLES:

12.1 Insulation Faults Between Strips :

The insulation test at 250 V, AC for 1 minute shall be conducted on all drums between each and every other strip in CTC stack. There shall be no fault in the insulation. In case of bunched (twin) CTC, this test shall also be conducted between two stack.

13. TEST CERTIFICATE:

Unless otherwise stated three copies of the test certificate shall be supplied along with each consignment,

In additional the supplier shall ensure to enclose one copy of test certificate along with their dispatch documents to ensure quick clearance of the material.

The test certificate shall bear the following information

AA 28129 : Paper covered continuously Transposed Copper Cable. (0.1% Proof Stress) (Rev. 04) Covered & Bare Dimension of cable, No. and size of individual conductor, increase in dimensions due to paper covering, number of paper layers and thickness of paper in each layer, grade of enamel and length of cable shall be indicated in the test certificate.

BHEL Order No.

Manufacturer's / Supplier's name

Trade mark, if any

Batch No./Lot No

Test results of enameled and covered transposed cable as per Cl. 5, 8 to 12.



Test certificates for compliance of characteristics of paper to BHEL Corporate Purchasing Specifications (CPS) No. AA 21111 and AA 21116.

14. PACKING AND MARKING:

The transposed cable shall be tightly and evenly wound, without twist, on drums in such a direction that when unrolled the exposed edge of the overlap of the outer layer of paper is towards the drum. The size of drum shall be selected from Annexure I. Drum flanges shall have an arrow mark showing the position of finishing end of cable.

Barrel dia 'C' of drum shall be at least 50 times of covered radial depth of cable subject to a maximum of 900 mm (Barrel 14) When specified on order, drums of barrel dia 1070 & 1140 mm shall be used. Out side flange dia A of drums can be reduced by the supplier considering the packing weight of CTC and capacity of the drum. How ever, it shall be ensured that cable is not packed up to the rim of the drum.

Before winding the insulated strip, a layer of polythene sheet or similar waterproof material shall be wrapped on empty drum. After winding the cable, the sheet edges shall be folded over the cable and then a polythene strip shall be wound on outside.

As a final protection, a layer of oiled canvas or similar waterproof material shall be wrapped over the polythene sheet, ensuring that no part of the cable is exposed.

Drums used for packing shall be made from seasoned wood. Circular disc separator shall be made from plywood.

Metal/Non –Metal straps used over, the drum shall be stamped/sealed with the manufacturer's identification marks. Similarly, end of the conductor shall also be stamped/sealed.

Each drum shall be labeled clearly stating the following information. The label shall preferably be cemented into a recess in the side of the flange of the drum.

AA 28129 - Paper Covered continuously Transposed Copper Cable. (0.1% Proof Stress)

BHEL Order No.
Manufacturer's Name / Suppliers Name

Maximum covered and bare dimension of cable, No. and size of individual conductor, increase in dimensions due to paper covering, No. of paper layers and thickness of paper in each layer, grade of enamel and length of cable.

Batch No./Lot No..
Net weight / Gross weight.

15. REFERRED STANDARDS (Latest Publication Including Amendments) :

- | | | | |
|-------------------|-----------------|-------------------|----------------|
| 1. AA 21111 | 2. AA 21116 | 3. AA 12024 | 4. IS:13730-17 |
| 5. IS:613 | 6. IEC 60317-17 | 8. IEC : 60317-27 | 9. IS:1060 |
| 10 IS:13730 Pt.27 | 11 IS:1608 | | |

ANNEXURE - I

Dimensions of Standard Drum

DIMENSION		Drum Designation						
		8	9	10	14A	14B	14C	14D
Outside Flange diameter	A	800	900	1000	1400	1400	1400	1400
Barrel dia	C	600	600	700	900	900	900	900
Overall width	D	440	440	660	440	710	910	580
Traverse	B	340	340	560	340	610	810	480
PCD of Driving Holes	J	300	300	600	600	600	600	600
Flange depth	G	88	138	138	238	238	238	238
Approximate Capacity in Kg.		300	480	890	1230	2200	2900	1730

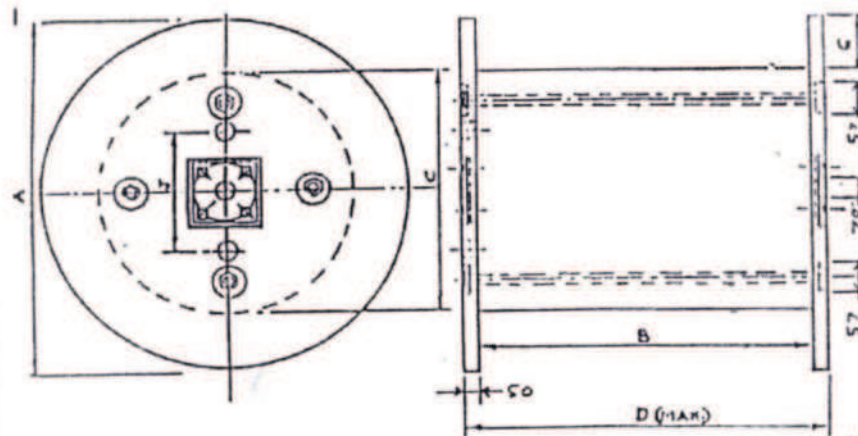

- NOTE:**
1. Partitions to hold multiple length in a drum shall be of 12.5 mm thick.
 2. Any fixing bolt used within a circle of 600 mm diameter shall not project outside flange surface.

Note:

1. Partitions to hold multiple length in a drum shall be of 12.5 mm thick.
2. Any fixing bolt used within a circle of 600 mm diameter shall not project outside flange surface.

Handwritten signature or initials.



CORPORATE PURCHASING SPECIFICATION

AA 281 27

REV NO. 06

PAGE 5 OF 10

10.3.2 Width of paper :

The width of paper shall be within the limits of 15 and 40 mm, both inclusive.

10.3.3 Arrangement of layers:

All the layers shall be applied in the same direction, all except the two outermost layers shall be butt wound and the two outermost layers shall be applied together with a staggering of 50% so that they are interlocked giving 50% overlap effect. Within each group the positions of the butt joints of any layer relative to the layer below shall be progressively displaced by approximately 30 percent of the paper width. There shall not be any gap between edges of adjacent turns of first butt wound paper layer i.e. enameled copper should not be visible. In subsequent butt wound layers, a possible gap of 0.5 mm maximum and overlap up to 1 mm between edges of adjacent turns shall be allowed.

10.3.4 Paper thickness for butt and overlap interlocked would layers:

Thickness of paper for butt wound layers shall be between 50 μ m and 100 μ m (both inclusive). Two outermost overlap interlocked layers shall be wound with paper of thickness between 75 and 125 microns (both inclusive). However, when radial insulation is 2.2 mm or more, 140 μ m paper for two outermost layers is allowed to avoid two paper covering operations due to availability of a maximum of 24 paper heads in the lapping machine of same manufactures. Special extensible high density and high mechanical strength paper meeting the requirements of clause 9 can be used in the two outermost interlocked layers.

10.3.5 Wax Coating :

When specified on order, a coating of paraffin wax to IS:4654 of thickness not exceeding 0.02 mm shall be applied on the bottom flat sides of fully paper covered width of the conductor

11. DIMENSIONS OF TRANSPOSED CABLES :

11.1 Method of Calculating Maximum Bare Axial Width (AW) :

$AW = 2(b + e) + F + \text{inter column paper if specified (100 } \mu\text{m thick)}$

Where :

AW = Max. bare axial width of transposed cable.

b = Maximum axial width of bare individual conductor
= Nominal width + Tolerance (from table 1 below)

e = Maximum increase in dimension due to enameling
(as per IS : 13730 Pt. 0 /Sec. 2 : 1993 (R2003), IEC 60317-0-2:2005)
= 0.11 mm for fine grades of covering

F = Free space allowance = 0.2 mm

**PRODUCT PURCHASING SPECIFICATION
TRANSFORMER ENGINEERING DEPARTMENT
BHEL BHOPAL**

Specification No. **TRE 218**
Page 1 of 1 Page
Rev. 01 Dt. : 08.09.2018

THERMALLY UPGRADED INSULATING KRAFT PAPER

1. **General** - This specification governs the quality of high density thermally upgraded insulating kraft paper for electrical purposes made entirely from soft-wood pulp manufactured by the sulphate process and upgradation to meet thermal stress. The kraft paper shall be dyed in green colour & shall be free from metallic particles. The material in insulating mineral oil shall have temperature index of at least 120.
2. **Usage** - This paper finds use in power transformer windings.
3. **Compliance with standards** – IEC:60554-3-5 grade 5A4-1M1 + Thermal upgradation.
4. **Sample for test** – 20 sheets of 300 x 300 mm shall be required for testing. Testing shall be as per IEC:60554-2.
5. **Properties** – Shall be as per Table 1 at page 2.
6. **Test certificates** - Unless otherwise stated, test certificates shall be supplied along with each consignment.

In addition, the supplier shall ensure to send one copy of test certificates along with their dispatch documents to facilitate quick clearance of the material.

The test certificates shall bear the information generally as per Table 1 along with nitrogen content.

7. **Packing & marking** - Packing shall be marked legibly at least with the BHEL spec. no., Order No., Quantity, Thickness & width, net/ gross weight & Date of manufacture.

REV	DATE	ALT CHD	REV-01	DATE 8.9.18	ALT CHD. <i>✓</i>	REV 00	NAME	SIGN	DATE
			COMPLETE SPECIFICATION REVISED.			PREP.	S.Sachdeva	-sd-	17.08.18
						CHD.	M.Kulkarni	-sd-	17.08.18

DWI/TCB/TRE/010

Kishu

**PRODUCT PURCHASING SPECIFICATION
TRANSFORMER ENGINEERING DEPARTMENT
BHEL BHOPAL**

Specification No. **TRE 218**
Page 2 of 2 Pages
Rev. 01 Dt. : 08.09.18

Table 1 – Properties of thermally upgraded insulating kraft paper

Property	Unit	Min.	Nominal	Max.
Nominal thickness	micron	45	50	55
		57	63	69
		68	75	82
		90	100	110
Grammage	g/m ²			
50 micron		47.5	50	52.5
63 micron		62.0	63	68.0
75 micron		71.5	75	78.5
100 micron	95.0	100	105.0	
Apparent bulk density	kg/m ³	950	1000	-
Air permeability	μm/Pa*s	0.05	-	0.10
Moisture content	%	-	-	8.0
Tensile index MD	Nm/g	93.0	-	-
Tensile index CD	Nm/g	35.0	-	-
Elongation MD	%	2.0	-	-
Elongation CD	%	4.0	-	-
Tear index MD	mN*m ² /g		-	-
Up to 75 micron		5.0		
Above 75 micron	mN*m ² /g	6.0		
Tear index CMD	mN*m ² /g		-	-
Up to 75 micron		6.0		
Above 75 micron	mN*m ² /g	7.0		
Electrical strength in Air	kV/mm	8.0	-	-
Ash content	%	-	-	0.5
Conductivity in aqueous extract	mS/m	-	-	4.0
pH in extract	-	6.0	-	8.0
Nitrogen content	%	1.0	-	-

TSJ

MANUFACTURING QUALITY PLAN

 M/s MEGHA ENGG. & INFRA LTD. BHEL, PIPLANI BHOPAL		Customer	Item	MQP No.:	Rev. No.	Rev. Date	BHEL W.O. No	Page
		M/s MEGHA ENGG. & INFRA LTD.	AUTO TRANSFORMER UPTO 765 KV	QA/TCB/31/744	03	25.08.2015	62007, 62009, 62010, 62011, 62014 & 62015-A-512-01	1
Quality Plan for :								
Sr.N	W.O. No.	Item & Rating						
1.	62007-A-512-01	14X500 MVA, 765/400/33 KV, 1- Ph Auto Transformer						
2.	62009-A-512-01	4X500 MVA, 400/220/33 KV, 3-Ph Auto Transformer						
3.	62010-A-512-01	2X315 MVA, 400/220/33 KV, 3-Ph Auto Transformer						
4.	62011-A-512-01	2X200 MVA, 400/132/33 KV, 3-Ph Auto Transformer						
5.	62014-A-512-01	4X500 MVA, 400/220/33 KV, 3-Ph Auto Transformer						
6.	62015-A-512-01	2X315 MVA, 400/220/33 KV, 3-Ph Auto Transformer						
CODE :								
Code 1. Indicates place where testing planned to be performed i.e. Inspection location.								
A	At Equipment Manufacturer's works							
B	At Component Manufacturer's works							
C	At Authorized Distributor's place							
D	At Independent Lab							
E	At Turn Key Contractor's place							
F	Not specified							
Code 3. Indicates who shall witness the tests i.e. Witnessing Agency								
P	Component Manufacturer itself							
Q	Component Manufacturer and Equipment Manufacturer or authorized representative							
R	Component Manufacturer, Equipment Manufacturer and Contractor							
S	Equipment Manufacturer itself							
T	Equipment Manufacturer and Contractor							
U	Equipment Manufacturer, Contractor and Customer (jointly)							
V	Third Party itself							
Code 5. Whether specific approval of sub-vendor, Component made is envisaged.								
E	Envisaged							
N	Not Envisaged.							
CMTC Component Manufacturer Test Certificate								
EMTC Equipment Manufacturer Test Certificate. CIP- Customer Inspection Point								

Code 2. Indicates who has to perform the tests i.e. Testing Agency

- J The Equipment Manufacturer
- K The component Manufacturer
- L The Third Party
- M The Turnkey Contractor

Code 4. Review of Test Reports / Certificates

- W By Equipment Manufacturer
- X By Contractor during product/process inspection
- Y By Customer during product/process inspection
- Z By Contractor and/or Customer during product/process inspection

Code 6. Whether test records required to be submitted after final inspection for issuance of CIP/MICC

- Y Yes
- N No

Mega Engineering and Infrastructure

EMail for mail

CAT-1

M. Gupta

(SATISH MATHUR)

Approved

II Approved, subject to final comments.

III Returned for correction / Re-issuance as per comments.

IV Accepted for information / ref. en.

V Not Approved / Rejected

19/05 (Date)

1. Manufacturing shall commence only after specific-written Confirmation / Manufacturing clearance.

2. The approval of drawings / documents by WUPPTCL / MEI, shall not absolve the contractor from its liability and responsibility for manufacturing, supplying and installing the system in accordance with the technical specifications codes / standards and satisfactory performance of equipment during the warranty defect liability period.

सुरेश कुमार गुप्ता / S.K. GUPTA

MANUFACTURING QUALITY PLAN

	BHARAT HEAVY ELECTRICALS LTD. BHOPAL Customer : M/s Megha Engg. Infra Ltd.	Item Auto Transformer (Up to 765 KV)	MQP No.: QA/TCB/3/1744	Rev. No. 02 03	Rev. Date 25.08.2015	BHEL W. O. No.: 62007, 62009, 62010, 62011, 62014 & 62015-A-512-01	Page 8
Components/ Operation & Description or Test	Type of check	Quantum of check/ Sampling with basis	Reference Document for Testing	Acceptance Norms	Format of Records	Applicable Codes 1 2 3 4 5 6	Remarks

Sl. No.	Components/ Operation & Description or Test	Type of check	Quantum of check/ Sampling with basis	Reference Document for Testing	Acceptance Norms	Format of Records	Applicable Codes	Remarks
d)	Insulation test for bunched conductor at 250 V for 1 min	Test	(for proof stress conductors) on each mother reel]				B K U/Q WIZ	--do-
e)	Check for Flexibility adherence of enamel covering, breakdown voltage test on enameled conductor & buckling Load Test.	Test					B K U/Q WIZ	--do-
f)	Check for Nomex Paper	Visual					B K P WIZ	Record Review
g)	Buckling load test for epoxy strip bounded conductor sample	Test					B K U/Q WIZ	Y CIP
1.3	PAPER COVERED COPPER CONTINUOUSLY TRANSPOSPOSED							
1.3.1	Visual and Dimensional check- Thickness, width of bare and enameled conductor, increase in dimensions due to enamel and due to paper covering, covered axial width and radial depth, arrangement of paper layers, proper storage and shelf life check for epoxy bonded CTC	Visual & Measurement	One sample per size per lot	BHEL Specification AA 28127 AA 28129 & TRE 036 BHEL P.O.			B K U/Q WIZ	CIP for first transformer each type, size & vendor as per contract & review for remaining Transformers and Record review for Off-shore materials



सुरेश कुमार गुप्ता / S. K. GUPTA
 उपाय महाप्रबंधक / Dy. General Manager
 गुणता आश्वासन-टी.सी.डी. ड्युअलिटी आश्वासन-TCB
 बी.एच.ई.एल., भोपाल / B.H.E.L., BHPAL

MANUFACTURING QUALITY PLAN

	BHARAT HEAVY ELECTRICALS LTD. BHOPAL Customer : M/s Megha Engg. Infra Ltd.	Item Auto Transformer (Up to 765 KV)	MQP No.: QA/TCB/31/744	Rev. No. 02	Rev. Date 25.08.2015	BHEL W. O. No.: 62007, 62009, 62010, 62011, 62014 & 62015-A-512-01	Page 9
SI. No.	Components/ Operation & Description or Test	Type of check	Reference Document for Testing	Acceptance Norms	Format of Records	Applicable Codes 1 2 3 4 5 6	Remarks

1.3.2	CHECK FOR :-	Test	BHEL Specification AA 28127 AA 28129 & TRE 036 BHEL P.O.	CMTc	K	U/Q	W/Z	-	N
a)	Resistivity at 20° C	Test	One sample per size per lot						
b)	Elongation (for Annealed conductor)								
c)	Proof stress (for proof stress conductor)								
d)	Check for Flexibility adherence of enamel covering, breakdown voltage test on enameled conductor &								
e)	Manual Operation of conductor for cured sample (Check for proper bonding of glue with conductor)								
f)	Insulation test on finished cable between enameled strips & between two stacks in case of bunched CTC		Shall withstand 250 V for 1 min. 1 Amp max changing current.						



S. K. GUPTA
 Dy. General Manager
 Quality Assurance-TCB
 BHEL, Bhopal

MANUFACTURING QUALITY PLAN

	BHARAT HEAVY ELECTRICALS LTD. BHOPAL Customer : M/s Megha Engg. Infra Ltd.	Item Auto Transformer (Up to 765 KV)	MQP No.: QA/TCEB/31/744	Rev. No.: .02 03	Rev. Date 25.08.2015	BHEL W. O. No.: 62007, 62009, 62010, 62011, 62014 & 62015-A-512-01	Page 10
Components/ Operation & Description or Test	Type of check	Quantum of check/ Sampling with basis	Reference Document for Testing	Acceptance Norms	Format of Records	Applicable Codes 1 2 3 4 5 6	Remarks

1.4	KRAFT INSULATING PAPER (USED FOR COVERING PICC & CTC)	Visual & Measurement	One sample per thickness per lot	BHEL Specn. AA 21111 AA 21116 BHEL P.O.	CMTC	B	K	P	W/Z	E	Y	Record Review
1.4.1	Visual check, & Measurement of Thickness	Visual & Measurement	One sample per thickness per lot	BHEL Specn. AA 21111 AA 21116 BHEL P.O.	CMTC	B	K	P	W/Z	E	Y	Record Review
	CHECK FOR :-	Test	One sample per thickness per lot	BHEL Specn. AA 21111 AA 21116 BHEL P.O.	CMTC	B	K	P	W/Z		N	Record Review
	Substance											
	Density											
	Moisture content / Water absorption											
	Air Permeability											
	Tensile index											
	Tear index											
	Electric strength in air											
	Ash Content											
	Conductivity											
	pH value											
	Heat stability (Type Test)											
1.5	CRGO STEEL											
1.5.1	Visual and Dimension check, Thickness, roll width, edge camber and waviness	Visual & Dimension	One sample per lot	BHEL Specn.AA 10905/ BP 10987 /BP 10988 / BP 10985 & BP 10984	CMTC EMTC	B A	K J	P U	W/Z W/Z	E -	N Y	CIP
1.5.2	CHECK FOR :-	Test	One sample per lot	-do-	CMTC EMTC	B A	K J	P U	W/Z W/Z		Y Y	CIP
	Specific total loss											
	Ductility											
	Stacking factor											
	Surface insulation resistivity											
	Magnetic permeability (Alternatively induction at 800 A / m)											
	Ageing test (Type test)											



सुरेश कुमार गुप्ता S. K. GUPTA
 Sr. Engineer / Dy. General Manager

Date: 25.08.2015



BHARAT HEAVY ELECTRICALS LIMITED, BHOPAL
QUALITY PLAN FOR CTC (Continuously Transposed Conductor)

QA PLAN NO: QC/TCB/QAP/BO/55 REV 01

DATE: 27/08/2010 PAGE 1 OF 3

SL	COMPONENT / OPERATION	CHARACTERISTICS	TYPE OF CHECK	REFERENCE DOCUMENT	QUANTUM OF CHECK	INSPECTION AGENCY	REMARKS
Raw material Inspection							
1	Kraft Insulating Paper	- Thickness - Routine tests - Type Test (test to be conducted for each manufacturer once in 5 Yrs.)	M/T	BHEL spec. AA 21111 AA 21116	1 Sample per lot for each thickness	CTC Vendor, BHEL/TPIA	- CHP For Record Review - CTC manufacturer shall send one set of samples (20 sheets of size 300mm x 300mm) and paper Manufacturer's test certificates for approval from BHEL Bhopal before use. Complete consignment details e.g. No. of reel, weight, invoice and linking paper shall be sent. - Paper from BHEL Bhopal approved source shall only be used.
2	CC Rod	- Surface finish. - Chemical composition: i) Copper including silver ii) Oxygen content. - Mass Resistivity. - Elongation	V/T	BHEL spec AA 12024	1 sample per lot.	CTC Vendor, BHEL/TPIA	- CHP For Record Review - Any discrepancy observed in CC rod at any stage of processing should be reported to BHEL with full details stating coil no. nature of defect with photographs. - CC Rod from BHEL Bhopal approved source shall only be used.
3	a) PVA based adhesive used for Kraft paper Bonding	i) Type grade & make. ii) Non volatile matter content, consistency, bond strength, pH Value, Compatibility with Transformer oil (Type test)	T	IS 2257	1 sample per lot.	CTC Vendor	Record review by CTC vendor
	b) Enamel and Epoxy coat	Colour, appearance, Solid contents, Viscosity, Flash point, storage and shelf life of enamel. Compatibility with Transformer Oil	T	CTC Vendor's spec.	1 sample per lot	CTC Vendor	

Handwritten signature and date
27/8/10

Handwritten signature

Handwritten signature
27/8/10

SL	COMPONENT / OPERATION	CHARACTERISTICS	TYPE OF CHECK	REFERENCE DOCUMENT	QUANTUM OF CHECK	INSPECTION AGENCY	REMARKS
In process inspection							
4	Manufacturing and storage area	Proper cleaning of copper dust and normal dust in plant and machinery	V	BHEL Spec AA28125, AA28128	100%	Vendor	- Surveillance Check By BHEL, TPIA/CQ
5	(a) Drawing Flattening and annealing	- Surface finish - Corner radius - Dimension - Elongation / Proof stress	V / M / T	AA 28127 AA 28129	100% mother reels	CTC Vendor	1-Surface defects like burrs, sharp edges, blisters, flakes, cracks, grease, foreign particles, and embedded impurities are not acceptable.
	(b) Enameling and Epoxy coating	- Surface finish of bare strip - Appearance of enameled strip - Bare and covered Dimensions - Shelf life - Tests: Resistance, Elongation, Proof stress (if applicable), springiness, flexibility and adherence, heat shock, resistance to solvents, BDV	V / M T	AA 28127 AA 28129 IEC 317-18 TRF 036	100% 3 samples per enamel setting (start, end and in between)	CTC Vendor	2-The conductor shall have smooth, bright and polished surface. 3-The enamel coating shall be smooth and continuous, free from streaks, blisters and foreign material. Complete records to be maintained by vendor for ensuring traceability from CC rod to Finish stage
	(c) Transposition and Paper Covering	- Visual Inspection - Dimensions of CTC stack - Pitch of Transposition - No. of layers, width and arrangement of paper lapping	V / M / T	AA 28127 AA 28129	100%	CTC Vendor, BHEL/TPIA	CHP for witness of covering for 2 reels of each size. The CTC stack shall be compact in both the directions; there shall be no damage to enamel.
Final inspection							
6	(a) Visual, Dimensions and Insulation covering	- Covered dimension of cable - Increase in dimension due to paper insulation. - Paper covering: Thickness, width, staggering and overlap - Inter column paper - Bare dimensions of cable - Pitch of transposition - Appearance of enameled conductor	V / M	AA 28127 AA 28129 IEC 317-18 TRF 036	3 samples per lot for each size	BHEL/TPIA	CHP for witness

[Handwritten signature]

[Handwritten signature]
27/8/10

[Handwritten signature]
27/8/10

SI	COMPONENT OPERATION	CHARACTERISTICS	TYPE OF CHECK	REFERENCE DOCUMENT	QUANTUM OF CHECK	INSPECTION AGENCY	REMARKS
		<ul style="list-style-type: none"> - Increase in thickness due to enameling and epoxy coating - Corner radius perpendicular ness of edges and merging - Bare thickness and width 					
	(b) Tests	<ul style="list-style-type: none"> - Resistivity - Elongation - Proof stress test (if applicable) - Flexibility and adherence - Springiness - Heat shock - resistance to solvent - BDV - Insulation test (between each and every other strip) at 250V - Epoxy curing check 	T	AA 28127 AA 28129 IEC 317-18 TRE 036	1 sample per lot per size	BHEL/TPIA	CHP for witness
7	Packing and Dispatch	<ul style="list-style-type: none"> - Provision of inter-layer paper. - Sufficient gap from drum brim to packed conductor top - Marking of winding direction. - Use of proper drum size - Proper identification - use of refrigerated container as per PO requirement 	V	AA 28127 AA 28129 TRE 036 TR 10133	100%	CTC Vendor	Surveillance check by BHEL TPIA

LEGENDS: V - VISUAL, M - MEASUREMENT, T - TEST, TPIA - THIRD PARTY INSPECTION AGENCY, CQ- BHEL CORPORATE QUALITY, CHP - CUSTOMER HOLD POINT (VENDOR CAN NOT PROCEED WITHOUT GETTING CLEARANCE FROM BHEL CQ TPIA)

<p><u>Changes in the revision:</u></p> <ul style="list-style-type: none"> - Remarks for clause 2 updated. - Clause 4 added and renumbering done. 	<p>Prepared By</p> <p><i>(Signature)</i></p> <p>(S.K.Bhargava)</p> <p>एल. ई. एल. भोपाल / B.H.E.L.</p> <p>ज. बी. बासफोर / J.B. BASFORE</p> <p>आर. भास्करावर (गुणवत्ता-टी.सी.बी.)</p>	<p>Approved By</p> <p><i>(Signature)</i></p> <p>(J.B. Basfore)</p> <p>जे. बी. बासफोर / J.B. BASFORE</p> <p>आर. भास्करावर (गुणवत्ता-टी.सी.बी.)</p> <p>Addl. General Manager(Quality-T.C.B.)</p> <p>वी. एच. ई. एल. भोपाल / B. H. E. L., BHOPAL</p>
--	--	--

(Handwritten signature)



CORPORATE PURCHASING SPECIFICATION

AA 120 24

Rev. No. 07

PAGE 1 OF 5

ELECTROLYTIC TOUGH PITCH COPPER WIRE BARS / INGOTS / CONTINUOUSLY CAST WIRE RODS / EXTRUDED SECTIONS

1.0 GENERAL:

This specification governs the quality requirements of electrolytic tough pitch copper wire bars, ingots, continuously cast wire rods (cleaned), and extruded sections for electrical purposes, with oxygen content of 400 ppm. max (Controlled oxygen).

2.0 APPLICATION:

2.1 Wire bars/rods / extruded sections are used for rolling / drawing into flats, strips, wires and bars etc for electrical application.

2.2 **Ingots are used for Castings.**

3.0 CONDITION OF DELIVERY:

3.1 **Wire Bars / Ingots : As cast.**

3.2 **Wire Rods – Cleaned : Continuously cast, rolled annealed.**

Total thickness of the copper oxide film shall not exceed 400 Å (Angstrom)

3.3 **Extruded Sections : As stated in BHEL order.**

Total thickness of the copper oxide film shall not exceed 400 Å (Angstrom).

4.0 COMPLIANCE WITH STANDARDS:

The material shall comply with the requirements of the following national standard and also meet the requirements of this specification.

4.1 Wire Bars / Ingots :

ASTM B5 - 2011	}	Standard Specification for
Gr : ETP-C11000	}	Electrolytic tough Pitch Copper
Oxygen - 400 ppm, max	}	Refinery Shapes

4.2 Wire Rod-Continuously Cast:

ASTM B49 - 2010	}	Copper Redrawn Rod for Electrical
Gr: ETP – C11040	}	Purposes
Oxygen - 400 ppm, max.	}	

Revisions :

Cl: 24.1of MOM of MRC-NFCW+HE

APPROVED :

INTERPLANT MATERIAL RATIONALISATION
COMMITTEE-MRC (NFCW+HE)

Rev. No. 07

Amd.No.

Reaffirmed

Prepared

Issued

Dt. of 1st Issue

Dt:06.06.2012

Dt :

Year :

BHOPAL

Corp. R&D

June, 1977

CORPORATE PURCHASING SPECIFICATION



4.2 Extruded Sections:

Assistance has been drawn from the following:

ASTM B49 - 2010	}	Copper Redrawn Rod for Electrical
Gr: ETP – C11040	}	Purposes
Oxygen - 400 ppm, max.	}	

5.0 DIMENSIONS AND TOLERANCES :

5.1 Sizes:

5.1.1 Wire Bars / Ingots:

The standard size and shape of wire bars/ingots shall be as per clause 7 of ASTM B5 and shall be as per Fig. 1 or 2 of the standard.

Any combination of the six standard sizes / shapes of wire bars/ingots as per Fig.1 or 2 of ASTM B5 is acceptable.

5.1.2 Wire Rods:

Wire rods shall be supplied in continuous length. The diameter of the bar to be supplied shall be as agreed to between BHEL and the manufacturer.

5.1.3 Extruded Sections:

Size of the extruded sections shall be as specified in BHEL order.

5.2 Tolerances:

5.2.1 Wire Bars/Ingots:

The permissible variation in dimensions and weights shall be as per ASTM B5.

5.2.2 Wire Rods:

The permissible tolerance on diameter shall be as per ASTM B49.

5.2.3 Extruded Sections:

As specified in BHEL order.

6.0 MANUFACTURE:

6.1 Wire Bars/Ingots :

Wire bars/Ingots shall be cast from ETP grade copper having oxygen content of 400 ppm, max.



CORPORATE PURCHASING SPECIFICATION

AA 120 24

Rev. No. 07

PAGE 3 OF 5

6.2 Wire Rods:

Wire rods shall be manufactured from continuously cast rods and annealed, from ETP grade copper having oxygen content of 400 ppm, max.

6.3 Extruded Sections:

Extruded sections shall be manufactured from ETP grade copper having oxygen content of 400 ppm, max

7.0 FREEDOM FROM DEFECTS:

7.1 Wire Bars/Ingots:

Wire bars/Ingots shall be substantially free of shrinks, holes, cold sets, pits, sloppy edges, concave tops, etc.

7.2 Wire Rods (Cleaned) & Extruded Sections:

The wire rods/Extruded sections shall have a smooth untarnished surface.

Surface shall be clean, smooth and free from pipes, laps, scale, flakes, cracks, kinks, twists, seams, damaged ends, excessive oil & grease and other injurious defects.

Total thickness of the copper oxide film shall not exceed 400 Å (Angstrom), when tested in accordance with ASTM B 49.

8.0 TEST SAMPLES:

One sample per melt shall be taken for chemical, mechanical and physical properties.

9.0 CHEMICAL COMPOSITION:

The chemical composition of copper shall be as follows:

Copper including silver – 99.90, minimum.

Oxygen content – 400 ppm, maximum.

10.0 PHYSICAL PROPERTIES:

Electrical resistivity when tested in accordance with ASTM E 1004 – Eddy Current probe Method, shall meet the following values.

10.1 Wire Bars/Rods/Extruded Sections:

The maximum mass resistivity for wire rods/bars shall be 0.15328 Ohm g/m² (conductivity 100% minimum IACS) at 20°C, annealed.



10.2 Ingots

The maximum mass resistivity for ingots and ingot bars shall be 0.15694 Ohm g/m² (Conductivity 97.66% minimum IACS) at 20^oC annealed.

*Note: Refer IS 613 for temperature correction factor.

11.0 MECHANICAL PROPERTIES

11.1 Elongation (Wire Rods-Continuously Cast & Extruded Sections).

When tested in accordance with IS: 1608 / ASTM B49, the elongation on 250 mm gauge length shall not be less than 30 percent.

11.2 Spiral Elongation Number (SEN) (Wire Rods – Continuously Cast):

The spiral elongation number (SEN) as per ASTM B49 shall be reported for information in the test certificate.

12.0 TEST CERTIFICATES:

Unless otherwise specified in the order five copies of test certificates shall be supplied along with each consignment, giving the following information.

In addition, the supplier shall ensure to enclose one copy of the test certificate along with the dispatch documents to facilitate quick clearance of the material.

The test certificate shall bear the following information:

AA 12024, Rev. No.06: Electrolytic Tough Pitch Copper Wire Bars/ Ingots/Continuously Cast Wire

BHEL Order No.

Supplier's Reference and Name

Heat No. /Charge No.

Results of Chemical composition, Physical & Mechanical properties and Dimensional measurements.

The spiral elongation number (SEN) as per ASTM B 49 shall be reported for information. Consignment/Identification, No.



CORPORATE PURCHASING SPECIFICATION

AA 120 24

Rev. No. 07

PAGE 5 OF 5

13.0 PACKING AND MARKING:

13.1 Packing:

13.1 Wire Bars / Ingots:

The wire bars/ingots shall be supplied in bundles.

13.1.2 Wire Rods (Continuously Cast) / Extruded Sections:

Wire rods / Extruded sections shall be supplied with wax coating, packed on strong wooden pellets with polyethylene and strapped with steel strips.

13.2 Marking :

Each bundle/package shall be marked with the following information :

AA 12024 : Electrolytic Tough Pitch Copper Wire Bars/ Ingots/Continuously Cast Wire Rods/Extruded Sections..

BHEL Order No

Consignment Identification No.

Size & Weight

Cast No.

Supplier's Name.

14.0 REFERRED STANDARDS (LATEST PUBLICATION INCLUDING AMENDMENTS):

1) ASTM: B5

2) ASTM: B49

3) ASTM: E 1004

4) IS: 613

5) IS: 1608



CORPORATE PURCHASING SPECIFICATION

AA 211 11

Rev. No. 06

PAGE 1 OF 4

KRAFT INSULATING PAPER - HIGH AIR PERMEABILITY

1.0 GENERAL:

This specification governs the quality requirements of kraft Insulating Paper for electrical purposes made entirely from soft-wood pulp manufactured by the sulphate process. The paper shall be manufactured in natural colour (undyed) and shall be free from metallic particles. The material in insulating oil shall have a temperature index of at least 105.

2.0 APPLICATION:

Used in the manufacturing of the following materials:

AA 21113: Medium phenolic coated soft kraft paper

AA 21114: Thick phenolic coated soft kraft paper

AA 28125: Paper covered rectangular copper conductor

AA 28128: Paper covered rectangular copper conductor-0.1% proof stress.

AA 28501: Paper covered stranded copper conductor

AA 28161: Paper covered round copper conductor

3.0 COMPLIANCE WITH NATIONAL STANDARDS:

The material shall comply, in general, with the requirements of the following National standards and also meet the requirements of this specification.

IS: 9335 (Part 3/Sec.5)-1985 | Cellulosic paper for electrical purposes. Part3: Spec.
Gr.: 5B2-2H1 | for individual materials. Sec.5: Special papers.

IEC 60554-3-5 - 1984 | Cellulosic paper for electrical purposes. Part3: Spec.
Gr.: 5B2-2H1 | for individual materials. Sec.5: Special papers.

4.0 DIMENSIONS AND TOLERANCES:

4.1 Sizes:

Thickness and width shall be as stated on BHEL order.

4.2 Thickness And Tolerances:

Nominal Thickness and Tolerances shall be in accordance with IEC 60554-3-5 as shown below:

Revisions :

Cl: e-mail dt: 19.01.2004 from BP

APPROVED :

INTERPLANT MATERIAL
RATIONALISATION COMMITTEE-MRC (E)

Rev. No. 06

Amd.No.

Reaffirmed

Prepared

Issued

Dt. of 1st Issue

Dt:15.01.2004

Dt :

Year :

BHOPAL

Corp. R&D

JUNE, 1982



<u>Nominal Thickness, micron</u>		<u>Tolerance, ±%</u>
<u>Over</u>	<u>Upto & Includ.</u>	
-	75	10
75	105	7
105	125	6
125	-	4

4.3 Width:

250, 450, 500, 610, 1015, 1145, 1320, 1400, 1780, 2030, 2285 and 2540mm with a tolerance of ± 5 mm. However any other width can also be ordered.

5.0 FINISH:

The paper shall have smooth but unglazed surface.

6.0 TEST METHODS:

Unless other wise specified, the tests shall be conducted in accordance with the relevant methods of IEC 60554-2/IS:9335 Part 2.

7.0 SAMPLE FOR TEST:

20 sheets of size 300 X 300 mm of ordered thickness suitably packed shall be supplied for testing and approval purposes. Machine direction shall be marked clearly on all the sheets.

8.0 PHYSICAL PROPERTIES:**8.1 Substance (grammage):**

<u>Nominal Thickness , μm</u>	<u>Substance ,g/m²</u>	<u>Tolerance, ± %</u>
25	20	10
45	36	10
50	40	10
55	44	10
63	50	5
65	52	5
75	60	5
100	80	5
125	100	5
140	112	5

Note: Substance for intermediate thickness shall be 0.8 times of the thickness, in micron.

8.2 Apparent Density : 0.80 ± 0.05 g/cm³

8.3 Moisture Content : 8%, max.

**8.4 Water absorption (Machine Direction Cross Machine Direction):**

Upto and including 40 micron thick	- 4 mm, min.
Above 40 micron to 55 micron thick	- 6 mm, min.
Above 55 micron to 75 micron thick	- 8 mm, min
Above 75 micron thick	- 10 mm, min

8.5 Air permeability : 0.5 to 1.0 $\mu\text{m}/\text{Pa.S}$ **9.0 MECHANICAL PROPERTIES:****9.1 Tensile Strength (Expressed as tensile index):**

Machine Direction (MD)	:	93 Nm/g, min.
Cross Direction (XD)	:	34 Nm/g, min.

9.2 Heat Stability (Type Test):

Paper shall be heated in air at $120^{\circ}\text{C} \pm 2^{\circ}\text{C}$ for 168 hours and following requirements shall be met.

- Increase in Conductivity of aqueous extract shall not be more than 23 ms/m.

9.3 Tear Index:

The material when tested shall show a minimum Internal Tearing Resistance as shown below, expressed as Tear Index.

<u>Weight, g/m^2</u>		<u>Machine Direction,</u> <u>$\text{m N m}^2 / \text{g}, \text{min}$</u>	<u>Cross Direction,</u> <u>$\text{m N m}^2, \text{min}$</u>
<u>Above</u>	<u>Upto & Includ.</u>		
30	80	5.0	6.0
80	120	6.0	7.0
120	-	8.0	9.0

10.0 ELECTRICAL PROPERTIES:**Electric strength in air:**

<u>Thickness, micron</u>		<u>BDV, (kV/mm), min.</u>
<u>Above</u>	<u>Upto & Includ.</u>	
-	90	7
90	120	6.5
120	-	6

Electric Strength shall be determined at room temperature after drying the paper for 1 to 2 hours at $105^{\circ}\text{C} \pm 2^{\circ}\text{C}$ and then tested within 2 minutes of removal from the oven.

**11.0 CHEMICAL PROPERTIES:**

Ash Content	:	1%, max.
Conductivity of 5% aqueous extract	:	10 mS/m, max.
pH of 5% aqueous extract	:	6 to 8

12.0 TEST CERTIFICATES:

Unless otherwise specified, three copies of test certificates shall be supplied along with each consignment .

In addition, the supplier shall ensure to enclose one copy of the test certificate along with their despatch documents to facilitate quick clearance of the material.

The test certificate shall bear the following information:

AA 21111 (Rev.No 06): Kraft Insulating Paper - High Air Permeability.

BHEL order No.

Manufacturer's/Supplier's Name.

Batch/Lot No.

Thickness and Width.

Net weight/No. of rolls.

Test values obtained and certificate for Physical, Mechanical, Electrical and Chemical Properties called for in this specification.

13.0 PACKING AND MARKING:

The paper shall be supplied in rolls tightly wound on suitable single piece hollow formers of 70, 75 or 90 mm inside diameter. The rolls shall be adequately wrapped to prevent damage during transport, handling and storage. The ends of the rolls shall be protected during packing to avoid any radial or telescopic deformation.

Each roll shall be clearly and indelibly marked with the following information:

AA 21111: Kraft insulating Paper-High Air permeability.

BHEL order No.

Manufacturer's / Supplier's Name

Batch/Lot No.

Thickness, Width and outside diameter.

Net weight.

14.0 REFERRED STANDARDS (Latest Publications Including Amendments) :

- | | | |
|------------------------|----------------------------------|-------------|
| 1) IS:9335, Part 2 & 3 | 2) IEC 60554-3-5 and IEC 60554-2 | 3) AA 21113 |
| 4) AA 21114 | 5) AA 28125 | 6) AA 28128 |
| 8) AA 28161 | | 7) AA 28501 |